

Pomoce do wymiarowania wnętrza kadłuba

Literatura:

T. C. Corke „Design of Aircraft”

D.P. Raymer „Aircraft Design, a Conceptual Approach”

D. Stinton „The Design of the Aeroplane”

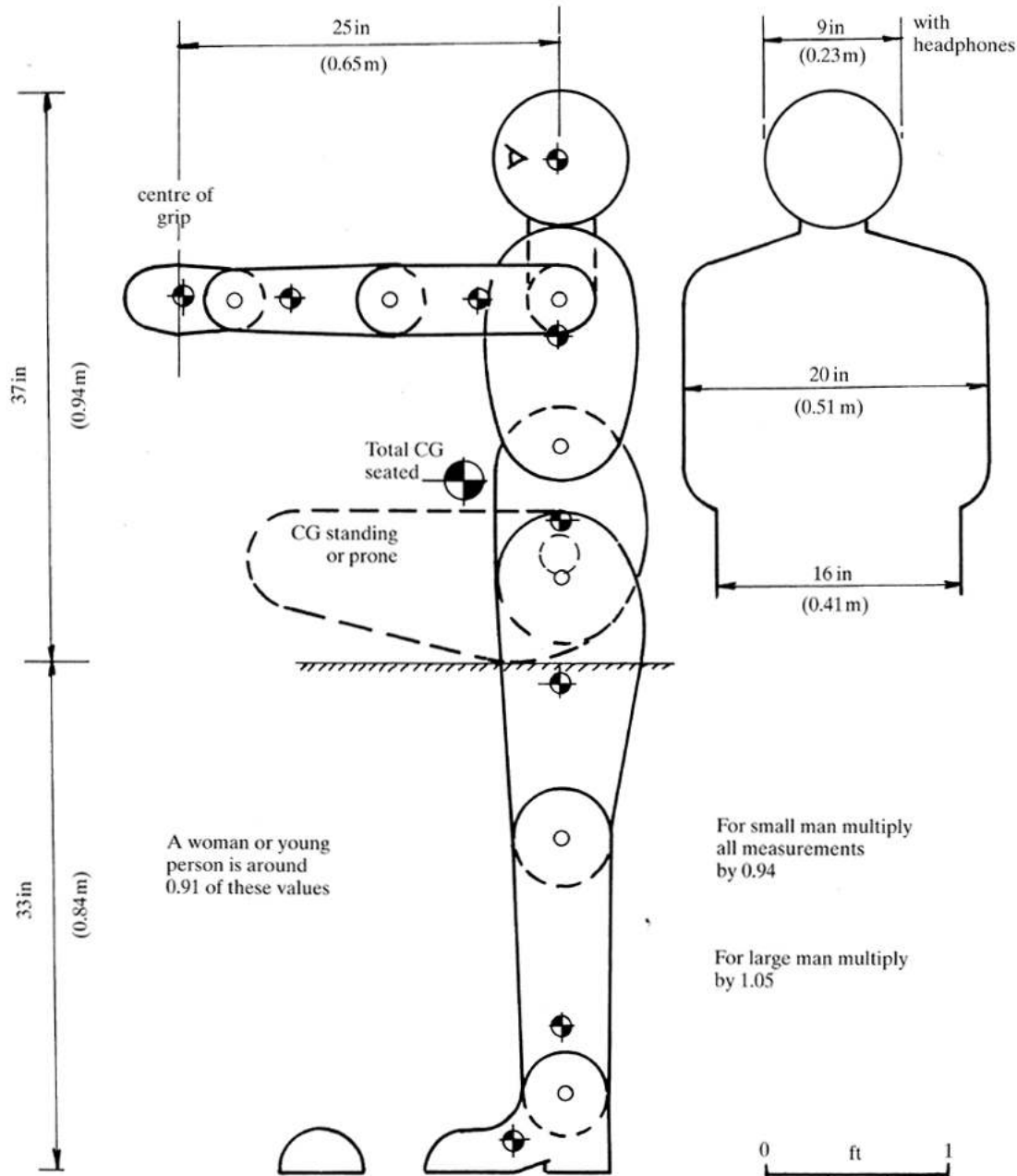

Part of (clothed) body	Per cent Weight	lb	kg
Head and neck	8.3	15	7
Upper trunk	27.2	49	22
Lower trunk	15.5	28	13
Thighs	22.2	40	18
Legs and feet	16.7	30	13.5
Upper arms	5.6	10	4.5
Forearms and hands	4.5	8	4
Total	100	180	82

For a small man multiply by 0.86; for a large man multiply by 1.14; for a woman or young person multiply by, say, 0.55

For small man multiply all measurements by 0.94

For large man multiply by 1.05

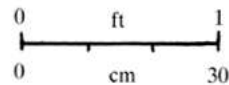

Stinton

make top line no higher than level with horizon when on ground in most tail-down attitude

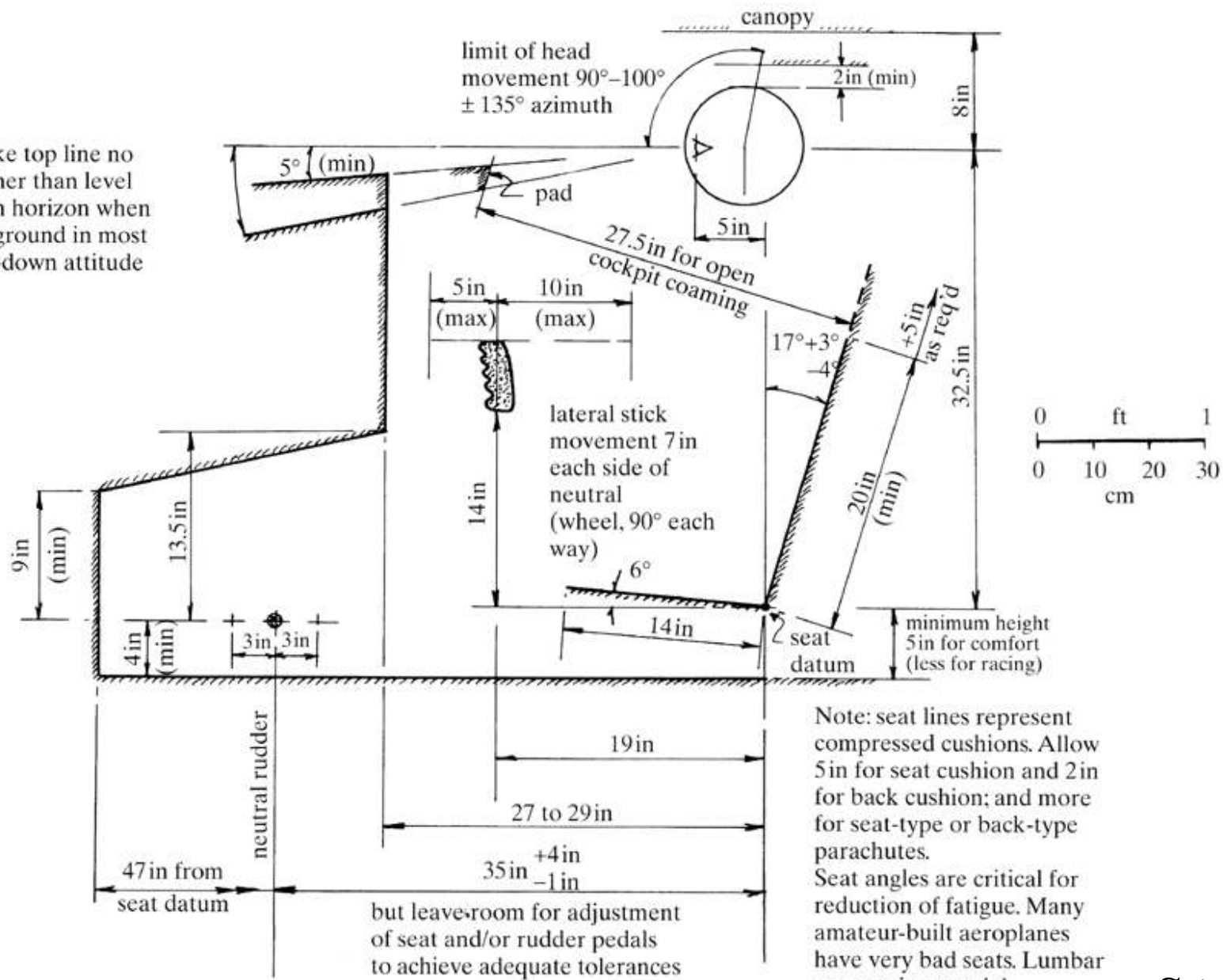

a

Stinton

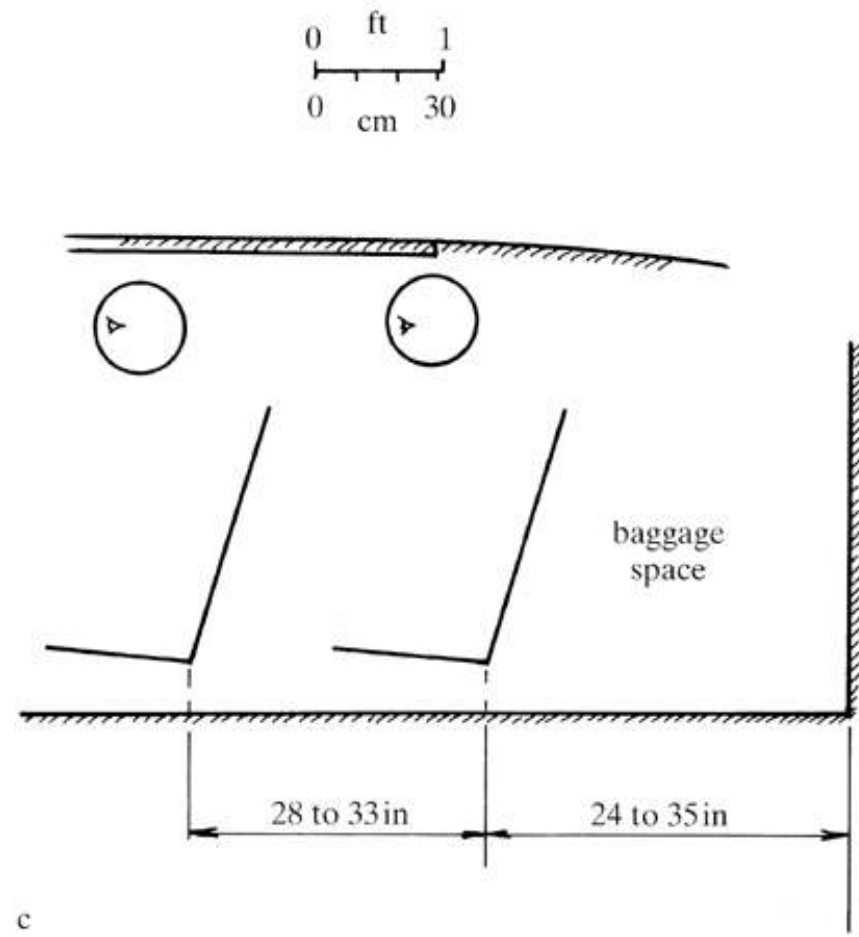
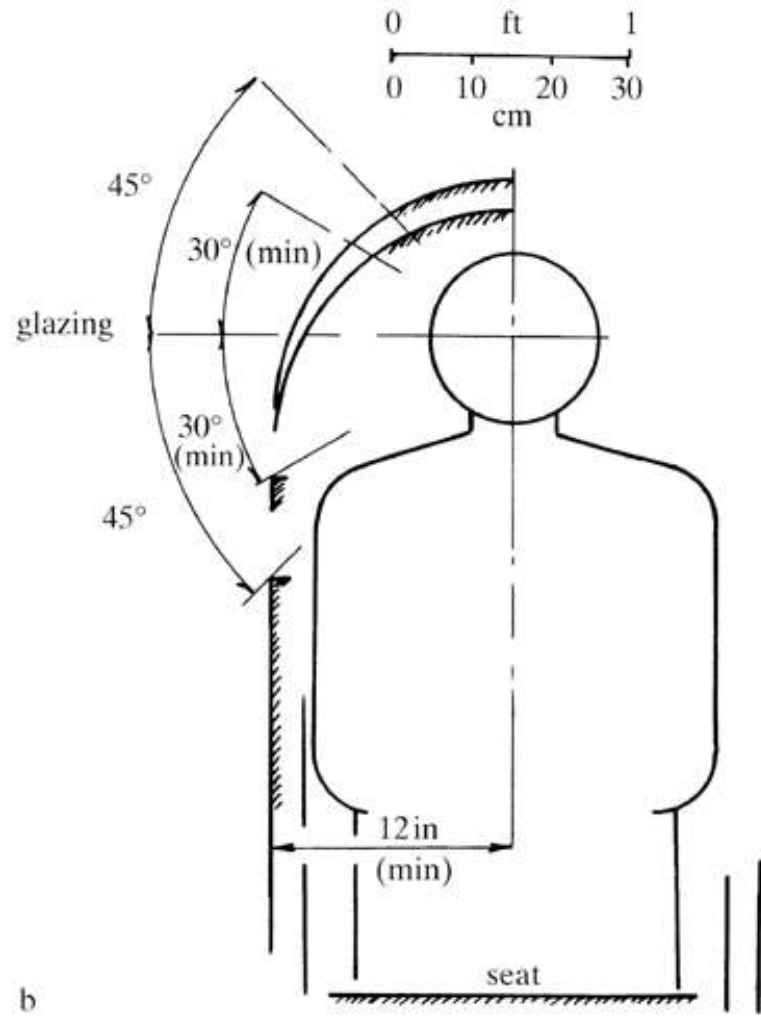

Stinton

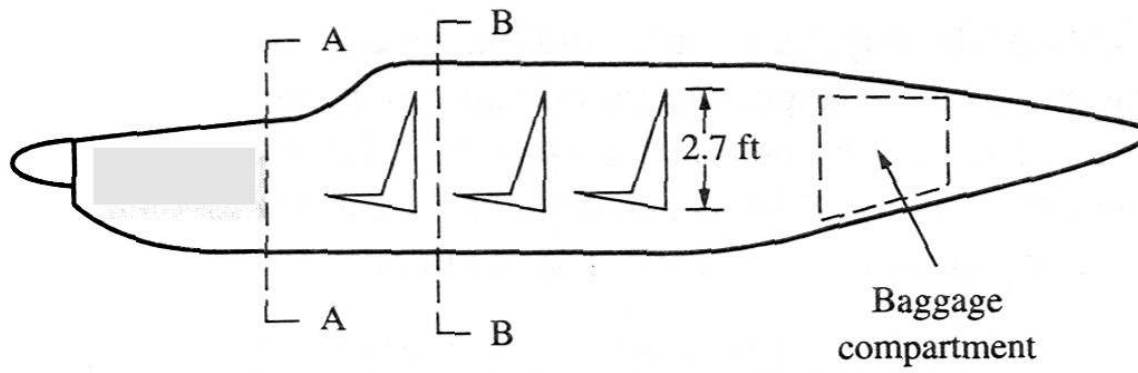

(a) Side view

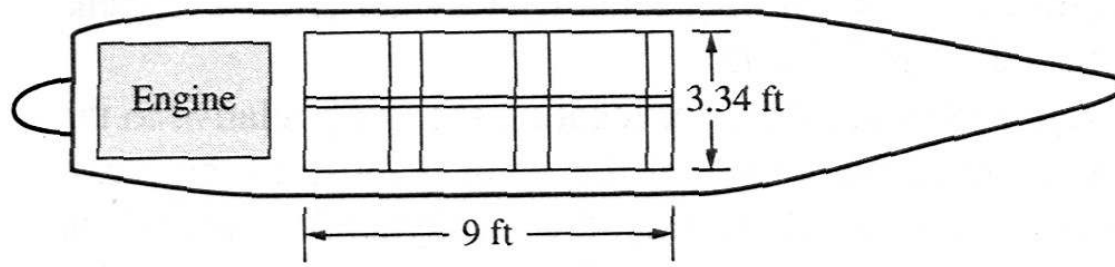

(b) Top view

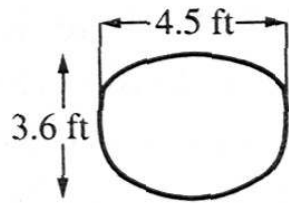

(c) Section A-A

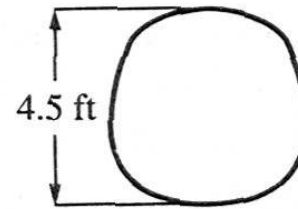

(d) Section B-B

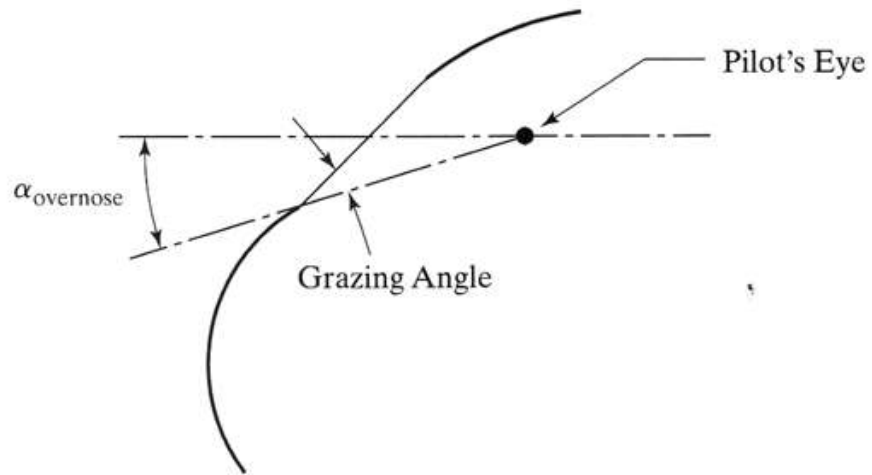

Side View

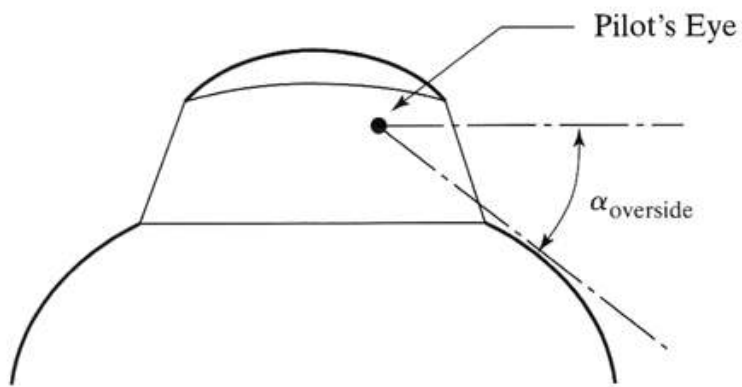

Front View

Kryteria kątów widzenia:

	$\alpha_{overnose}$	$\alpha_{overside}$
Military Transports/Bombers	17°	35°
Military Fighter	11°–15°	40°
General Aviation	5°–10°	35°
Commercial Transport	11°–20°	35°

Corke

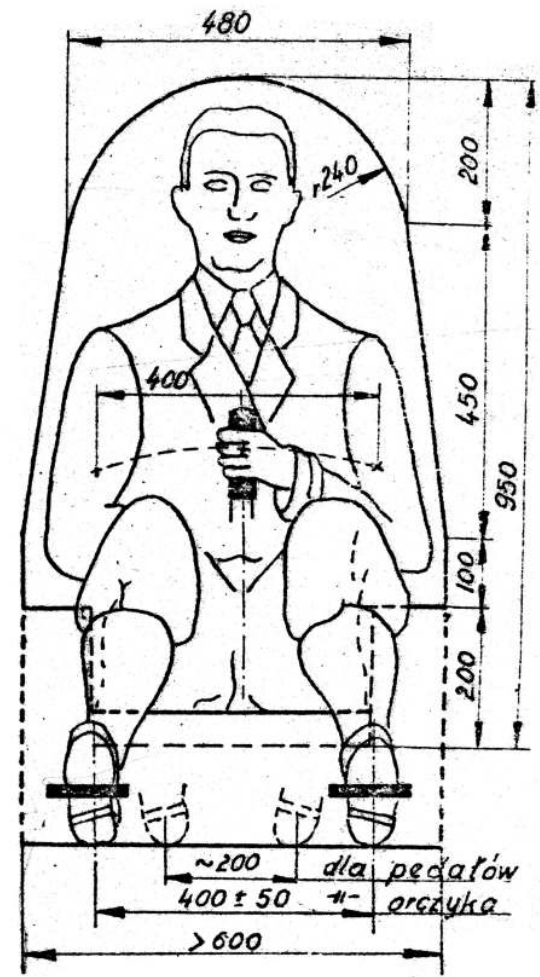
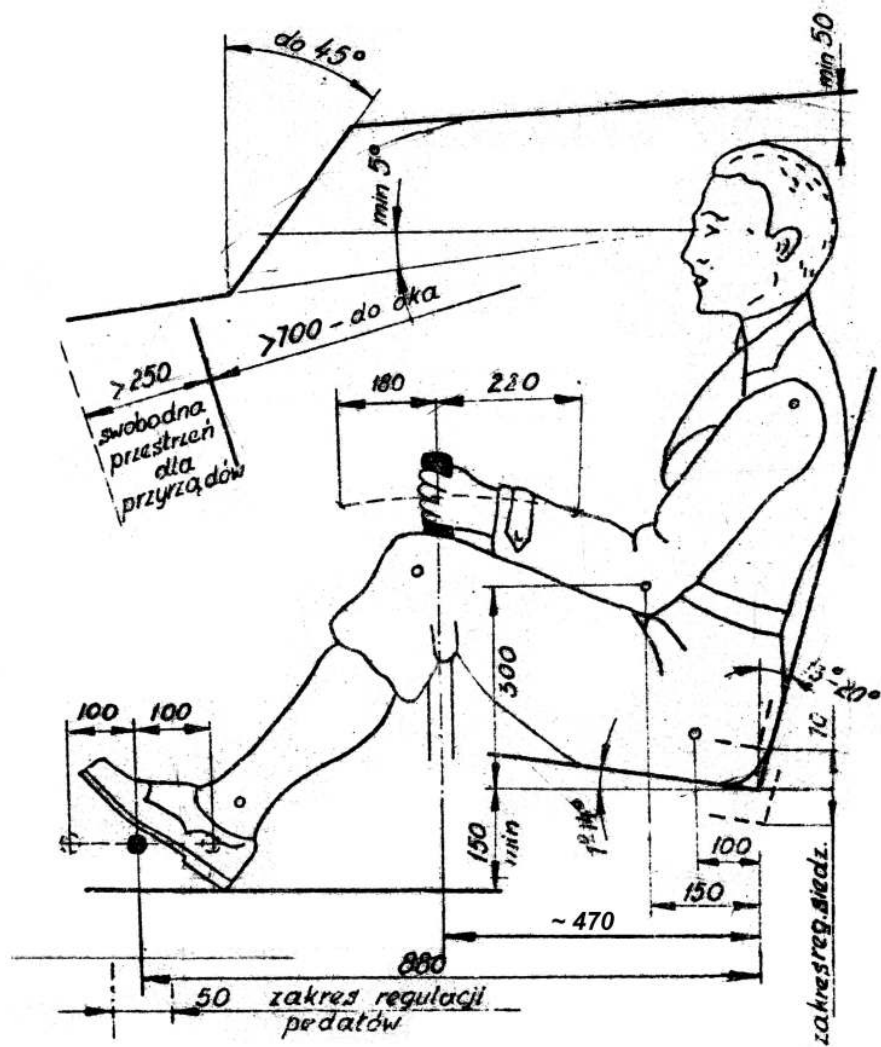

Schemat pojedynczego pomieszczenia pilota o minimalnym gabarycie poprzecznym i podłużnym

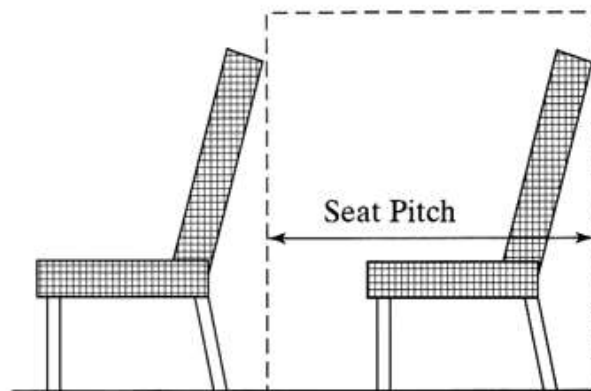
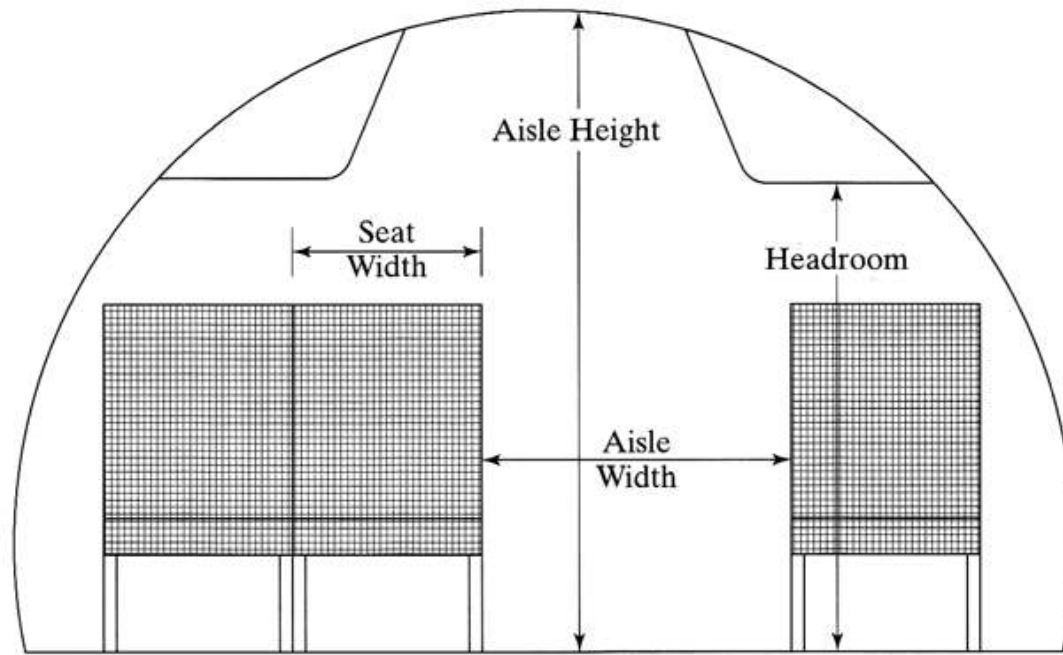

Corke

Minimalne wymagania wymiarujące kabiny pasażerskie

	Long Range			Short Range		
Seat Width	17	28	[in]	16	18	[in]
Seat Pitch	34	40	[in]	30	32	[in]
Headroom	65		[in]			[in]
Aisle Width	20	28	[in]	15		[in]
Aisle Height	76		[in]	60		[in]
Passengers/Cabin	10	36			50	
Passenger/Lavatories	10	20		40	50	
Galley Volume/Passenger	1	8	[f ³]	0	1	[f ³]
Baggage/Passenger	40	60	[lbs]	40		[lbs]

Minimalne wymagania wymiarujące kabiny pasażerskie (jedn. SI)

	Daleki zasięg			Mały zasięg		
Szerokość siedzenia	0.43	0.71	[m]	0.41	0.46	[m]
Odległość między siedzeniami	0.86	1.02	[m]	0.76	0.81	[m]
Wysokość kabiny nad siedzeniem	1.65	0.00	[m]			[m]
Szerokość przejścia	0.51	0.71	[m]	0.38		[m]
Wysokość przejścia	1.93	0.00	[m]	1.52		[m]
Liczba pasażerów/przedział	10	36			50	
Liczba pasażerów/toaletę	10	20		40	50	
Objętość kuchni/pasażera	0.03	0.23	[m ³]	0.00	0.03	[m ³]
Bagaż osobisty	18.14	27.22	[kg]	18.14		[kg]

Wymiary kabin

TABLE 5.2: Passenger aircraft seating arrangements.

Passenger No.	Fuselage Diam. (in.)	Aisle Seating	Examples
4–9	64	1 + 1	Citation V
10–20	58	1 + 1	Beech 1900
	94	2 + 1	Gulfstream II
20–50	91	2 + 1	Saab 340
50–75	106	2 + 2	DHC-8/300
75–190	130	2 + 3	MD-80
	148	3 + 3	Boeing 757
190–270	198	2 + 3 + 2	Boeing 767
	222	2 + 4 + 2	Airbus A300
270–360	222	2 + 4 + 2	Airbus A330
	236	2 + 5 + 2	DC-10, L-1011, Boeing 777
360–450	256	3 + 4 + 3	Boeing 747

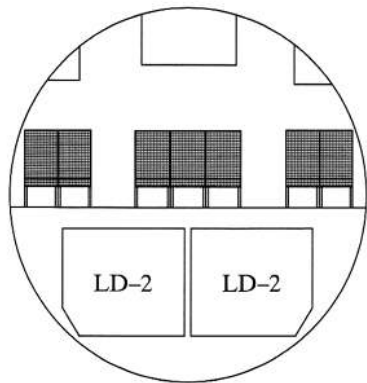

Boeing 767

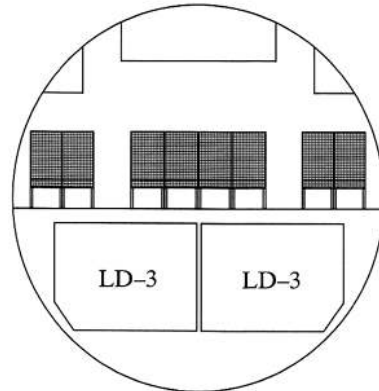

Airbus A300

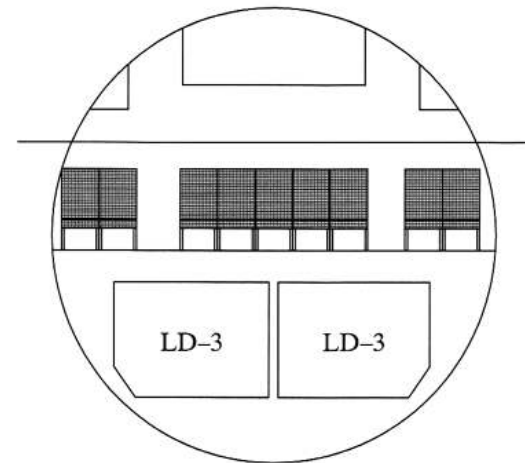

Boeing 777

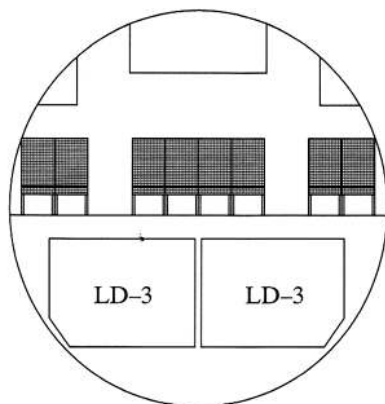

Lockheed L-1011

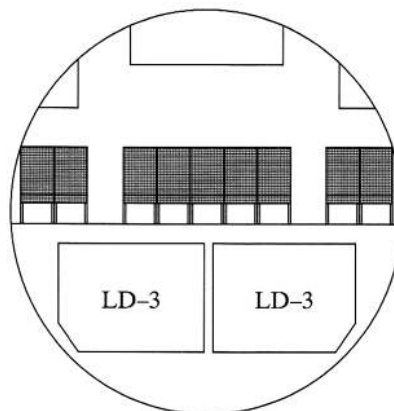

McDonnell Douglas DC-10

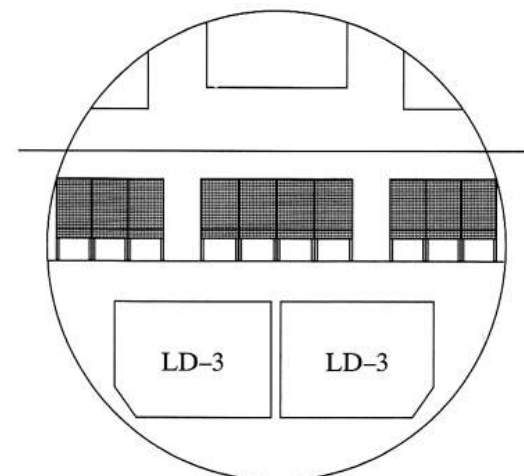

Boeing 747

Corke

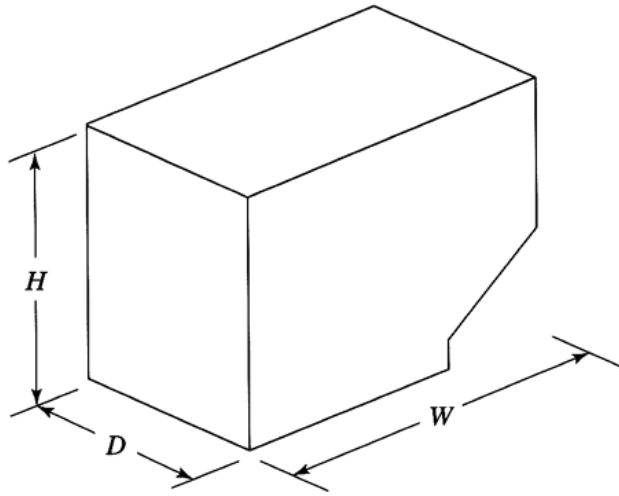

LD-2, LD-3

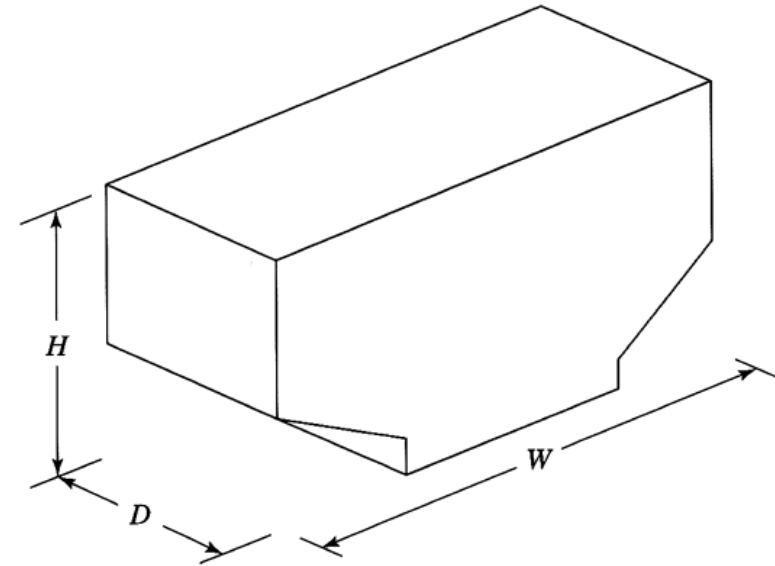

LD-8

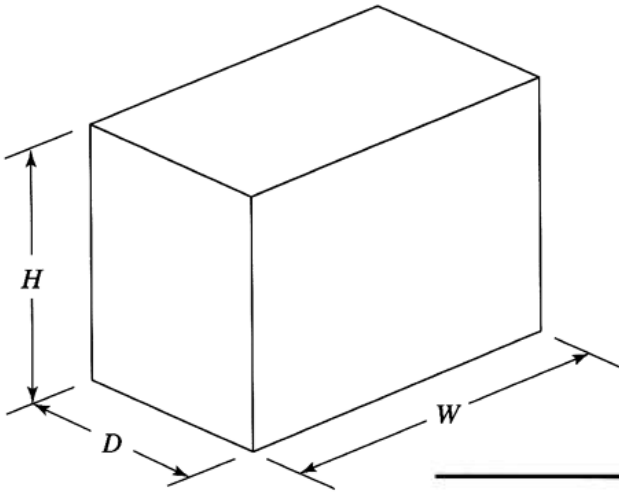

LD-4, LD-5

Corke

Type	Height (in.)	Width (in.)	Depth (in.)	Volume (f ³)	Gross Wt. (lbs)
LD-2*	64.0	61.5	60.4	120	2700
LD-3*	64.0	79.0	60.4	156	3500
LD-4	64.0	96.0	60.4	195	5400
LD-5	64.0	125.0	60.4	279	5400
LD-8*	64.0	125.0	60.4	245	5400

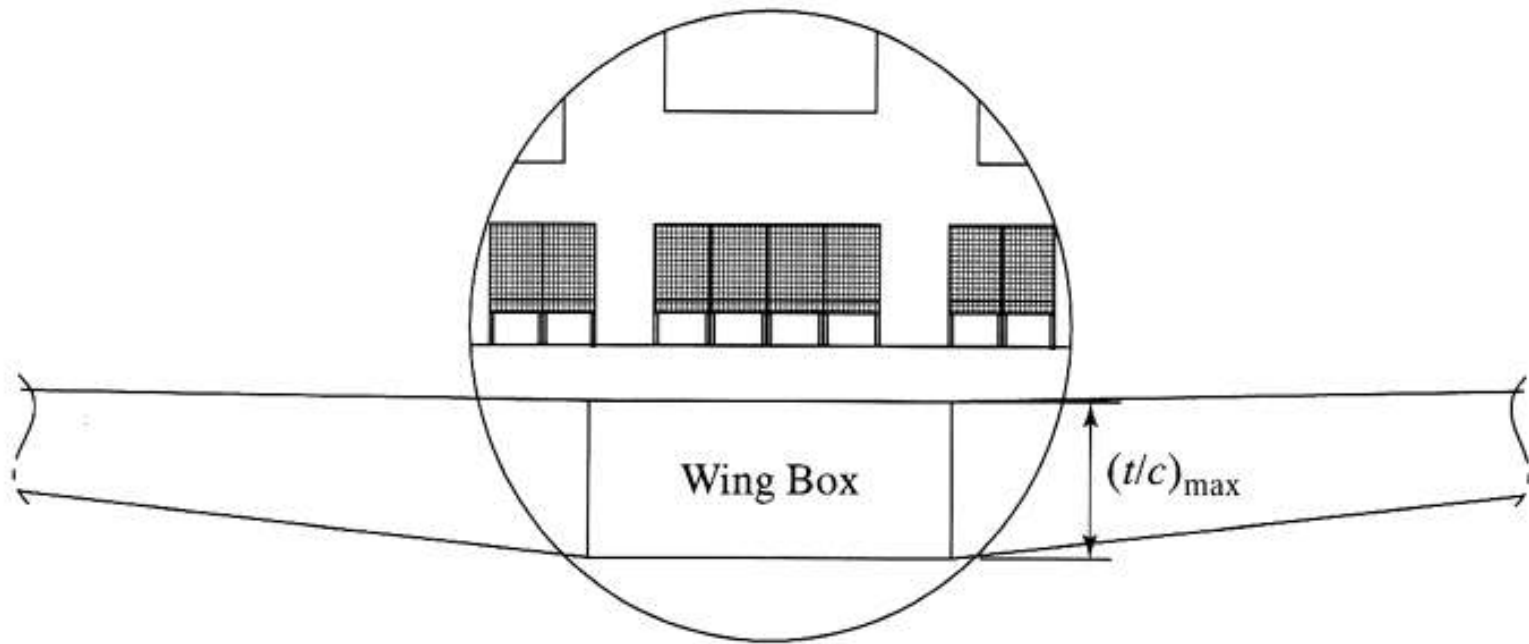

Corke